

Agri-Fab®

**OWNERS
MANUAL**

**Model No.
45-0175**

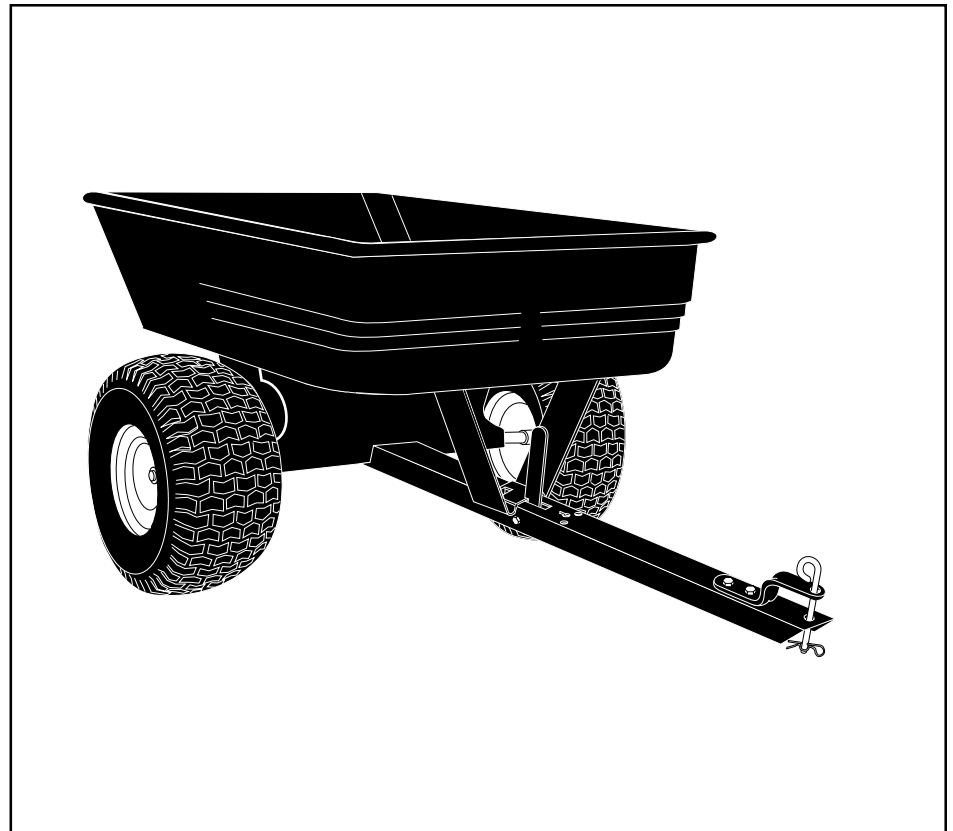

**EXPLORER "10"
POLY DUMP CART**

CAUTION:
Read Rules for
Safe Operation
and Instructions
Carefully

- Assembly
- Operation
- Maintenance
- Repair Parts

SpeedEPart *the fastest way to purchase parts* www.speedepart.com

SAFETY RULES

Remember, any power equipment can cause injury if operated improperly or if the user does not understand how to operate the equipment. Exercise caution at all times when using power equipment.

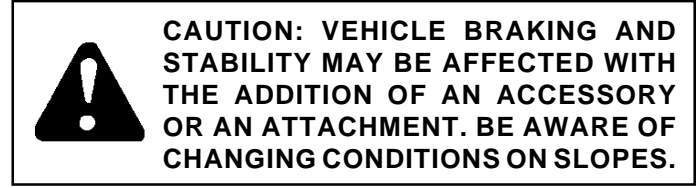

Exercise caution at all times when using power equipment.

- Read this owners manual before attempting to assemble or operate the cart.
- Read the vehicle owners manual and know how to operate your vehicle before using the cart attachment.
- Do not at any time carry passengers in this cart. It has not been designed to carry passengers.
- Never allow children to operate the vehicle or the cart attachment.
- Do not allow adults to operate the vehicle or cart attachment without proper instructions.
- Always begin with the transmission in first (low) and gradually increase speed as conditions permit.
- Tow the cart at reduced speed over rough terrain and hillsides or near creeks and ditches to prevent tipping over and loss of control. Do not drive too close to a creek or ditch.
- Vehicle braking and stability may be affected with the attachment of this cart. Do not fill cart to maximum weight capacity without checking the capability of the towing vehicle to safely pull and stop with the cart attached.
- Before operating vehicle on any grade (hill) refer to the safety rules in the vehicle owner's manual concerning safe operation on slopes. Refer also to the slope guide on page 11 of this manual. **Stay off steep slopes!**
- Do not tow this cart on highways or on public thoroughfares.
- Maximum towing speed is 10 m.p.h.
- Follow maintenance and lubrication instructions as outlined in this manual.

CARTON CONTENTS (Loose Parts)

- | | | |
|------------------------|--------------------|---------------------|
| 1. Poly Tray | 5. Axle | 8. Latch Lock Lever |
| 2. Wheel Support | 6. Wheels (2) | 9. Hitch Bracket |
| 3. Latch Stand Plate | 7. Draw Bar Tongue | |
| 4. Latch Stand Bracket | | |

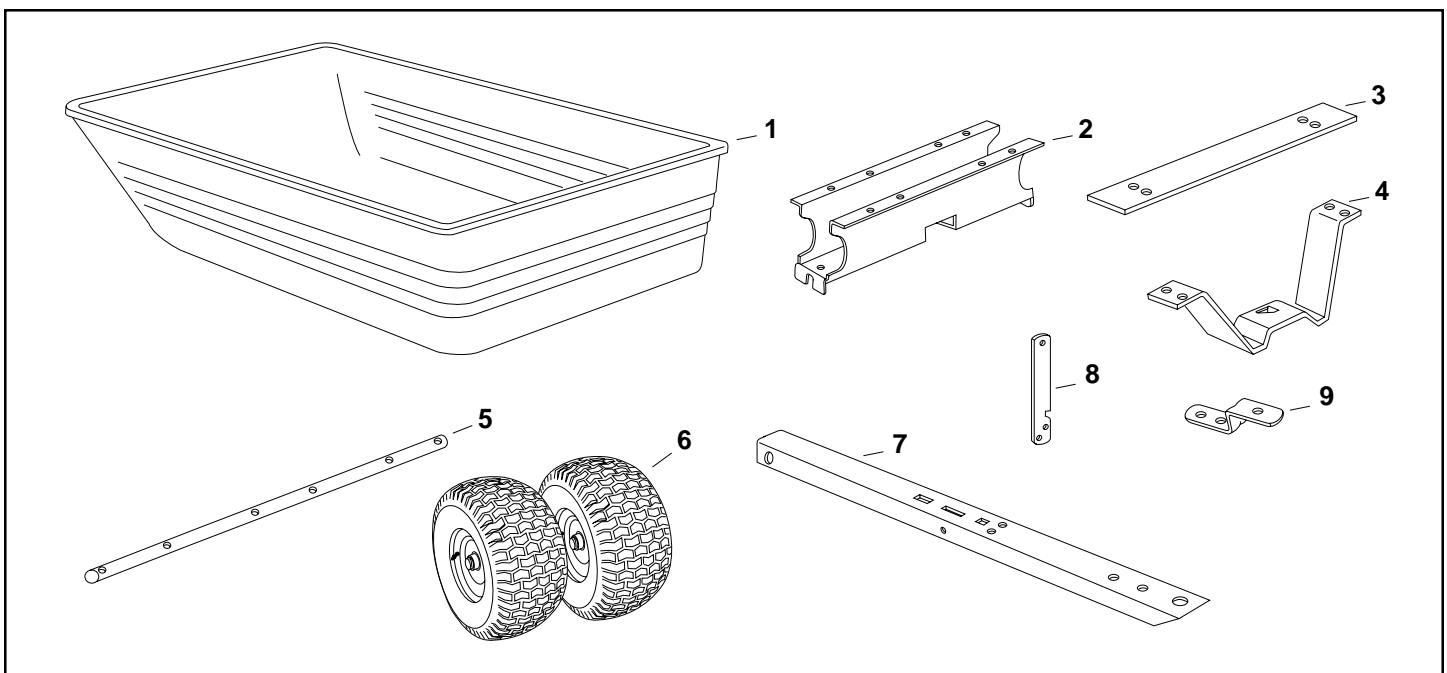

CARTON CONTENTS

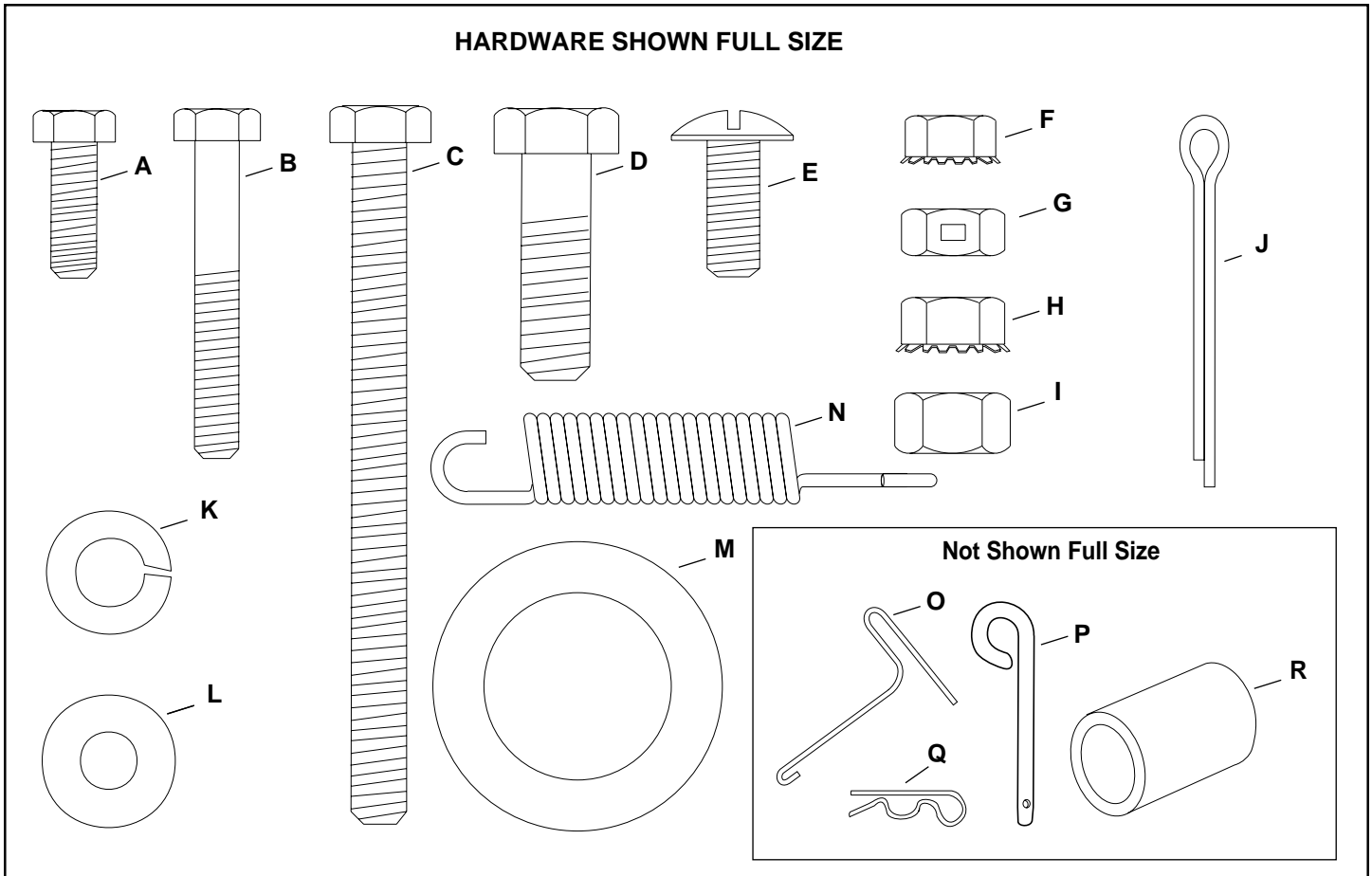

HARDWARE PACK

Ref. No.	Quant.	Description
A	4	Hex Bolt, 1/4" x 3/4"
B	4	Hex Bolt, 1/4" x 1-3/4"
C	1	Hex Bolt, 5/16" x 3-3/4"
D	2	Hex Bolt 3/8" x 1-1/4"
E	8	Truss Head Bolt 5/16" x 3/4"
F	8	Hex Nut, 1/4"
G	1	Lock Nut 5/16"
H	10	Hex Nut, 5/16"
I	2	Hex Nut 3/8"
J	2	Cotter Pin, 1/8" x 1-1/2"
K	2	Lock Washer, 3/8"
L	4	Flat Washer, 1/4"
M	4	Flat Washer, 1"
N	1	Extension Spring
O	1	Spring Puller Tool
P	1	Hitch Pin
Q	1	Hair Cotter Pin 1/8"
R	2	Spacer Tube

ASSEMBLY INSTRUCTIONS

TOOLS REQUIRED FOR ASSEMBLY

- (1) Screwdriver
- (1) Pliers
- (2) 7/16" Wrenches
- (2) 1/2" Wrench
- (2) 9/16" Wrenches

1. Remove the hardware pack and all loose parts from the carton. Be sure the carton is empty before discarding.
2. Lay out and identify all the parts and hardware as shown on pages 2 and 3.
3. Place the latch lock lever through the slot in the draw bar tongue as shown in figure 1. Assemble the 5/16" x 3-3/4" hex bolt through the tongue, the lever and two 5/16" hex nuts (one on each side of the lever). Assemble the 5/16" hex **lock** nut onto the end of the bolt and **tighten** so that the bolt can still rotate freely. **Tighten** the two 5/16" hex nuts against the sides of the latch lock lever so that the lever is centered in the slot. See figure 1.

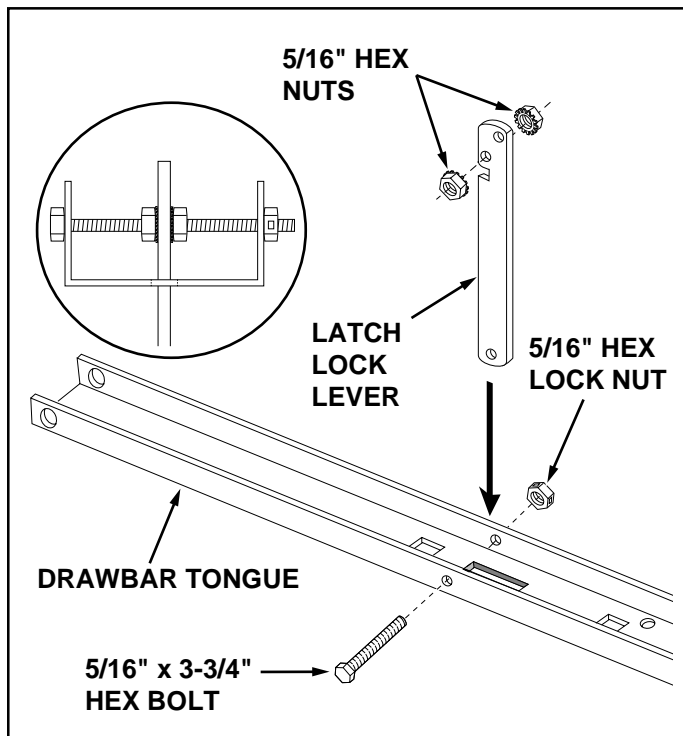

FIGURE 1

4. Hook the **short** end of the spring into the hole in the latch lock lever. Use the spring puller tool to hook the **long** end of the spring into the square hole in the tongue. The spring puller tool can be stored when finished. See figure 2.

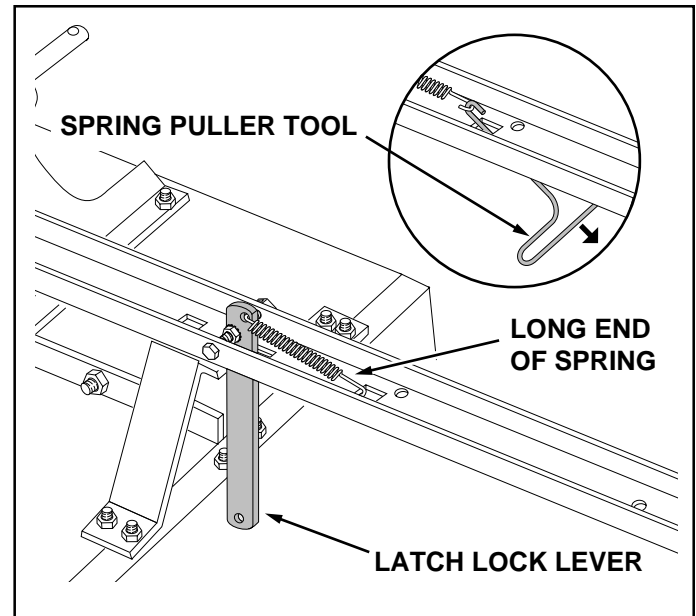

FIGURE 2

5. Assemble the hitch bracket to the drawbar tongue, using two 3/8" x 1-1/4" hex bolts, 3/8" lock washers and 3/8" hex nuts. **Tighten**. See figure 3.
6. Assemble hitch pin to tongue/ hitch bracket and secure with 1/8" hair cotter pin. See figure 3.

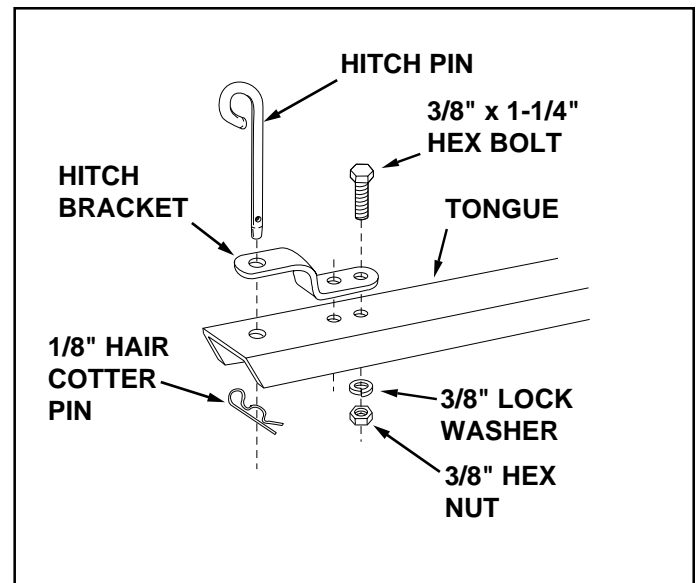

FIGURE 3

7. Assemble the axle and drawbar tongue to the wheel support, with the open side of tongue facing away from the wheel support. Fasten the axle to the wheel support using four 1/4" x 1-3/4" hex bolts and 1/4" hex nuts. **Tighten.** See figure 4.

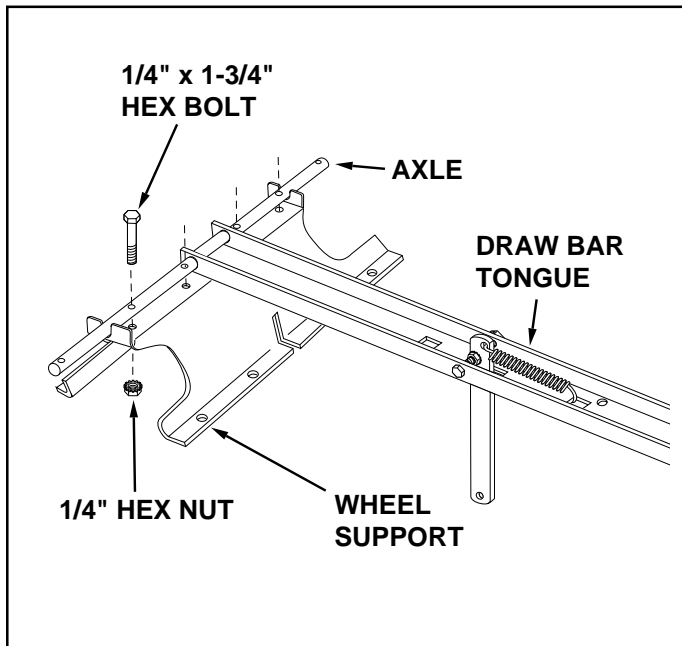

FIGURE 4

8. Assemble a spacer tube, a 1" flat washer, a wheel (valve stem facing out) and another 1" flat washer onto the axle as shown in figure 5. Insert a cotter pin through the axle, spreading the ends. Repeat on other end of axle.

NOTE: Use the grease fitting to fill the wheel hub with automotive type grease after the wheel is assembled onto the axle.

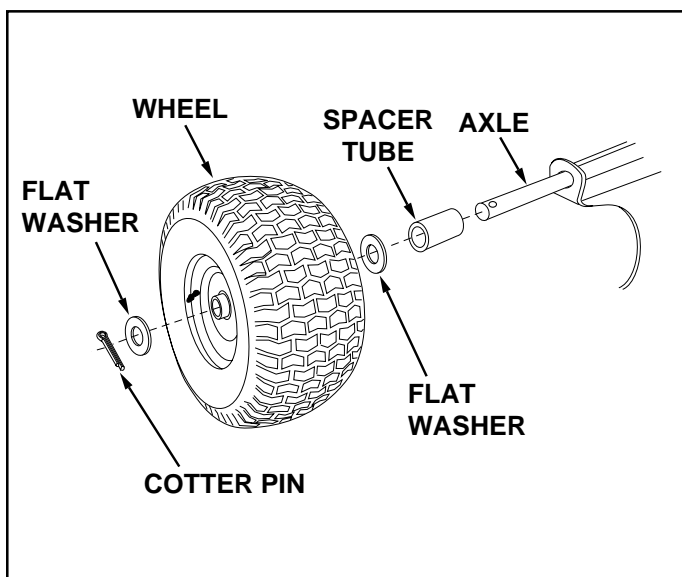

FIGURE 5

9. Assemble the latch stand plate and the latch stand bracket to the bottom of the poly tray using four 1/4" x 3/4" hex bolts, 1/4" flat washers and 1/4" hex nuts. The aligning tab on the bottom of the latch stand bracket must be towards the rear of the cart. **Tighten.** See figure 6.

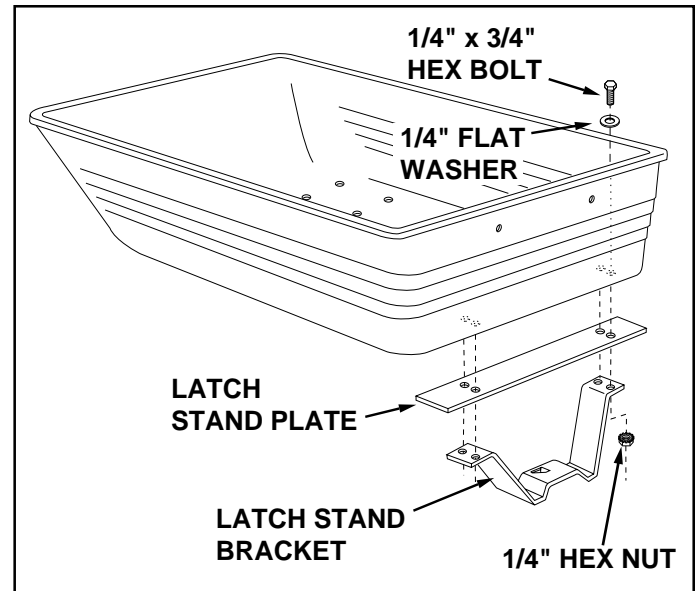

FIGURE 6

10. Place the poly tray down onto the wheel support, positioning it so that the latch stand bracket snaps under the latch lock lever. Fasten the tray to the wheel support using eight 5/16" x 3/4" truss head bolts and 5/16" hex nuts as shown in figure 7. **Tighten.**

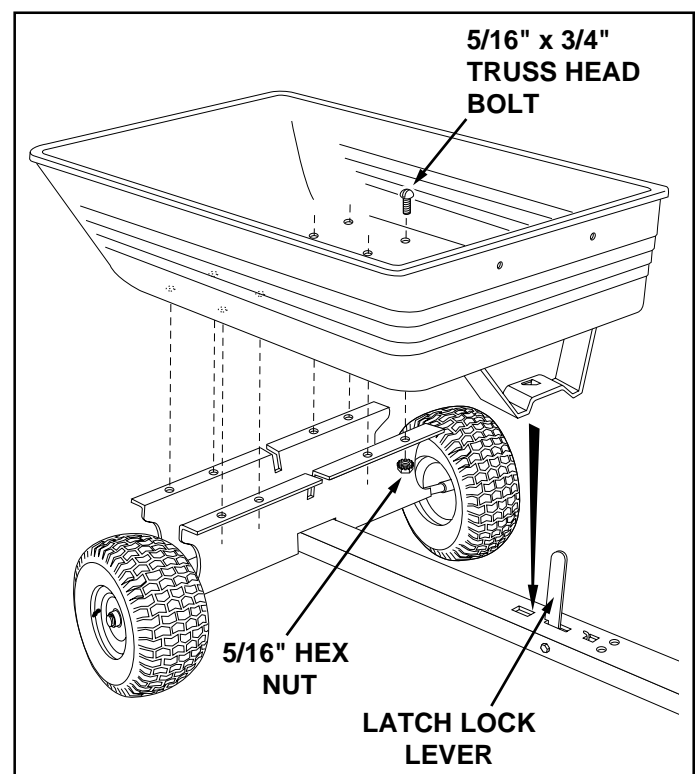

FIGURE 7

OPERATION



CAUTION: VEHICLE BRAKING AND STABILITY MAY BE AFFECTED WITH THE ADDITION OF AN ACCESSORY OR AN ATTACHMENT. BE AWARE OF CHANGING CONDITIONS ON SLOPES.

1. Refer to the vehicle owners manual for instructions on safe operation on slopes.
2. Use the slope guide provided on page 11 of this manual to determine whether slope angle is too steep for safe operation.
3. For best handling and traction, distribute the weight of the load evenly in the cart.
4. Always test to make sure your vehicle has adequate towing and braking capabilities whenever hauling a substantial amount of weight in your cart. Use extra caution when operating on slopes.



NOTE

DO NOT EXCEED WEIGHT CAPACITY OF CART

(See the specifications on this page.)

One cubic foot of dirt weighs approximately 150 lbs.

5. To dump material from the cart, release the spring latch on the tongue by pulling the latch lock lever forward, away from the cart. The cart bed will then tilt backwards to empty its contents. After emptying, pull the front of the bed down toward the cart tongue until the latch snaps into place.
6. The maximum towing speed for this cart is 10 m.p.h.



CAUTION: TO AVOID POSSIBLE INJURY, BEFORE RELEASING THE LATCH BE SURE THAT NO ONE IS NEAR THE CART.

MAINTENANCE

1. At the beginning of each season, using a light machine oil, lubricate the latch, the latch pivot bolt, and the area of the axle where the draw bar tongue pivots .
2. Grease the wheel bearings periodically. Apply an automotive wheel bearing type grease through the grease zerk in the wheel hub.
3. Check periodically for loose bolts.
4. Keep tires filled. Do not exceed maximum tire pressure of 10 Lbs.

CART SPECIFICATIONS

Tires: 20" x 10" Pneumatic
Axle: 1" Dia. Steel
Capacity: Up to 650 Lbs. Max.
Approx. Sh. Wt. 100 Lbs.

NOTES

REPAIR PARTS FOR POLY CART MODEL 45-0175

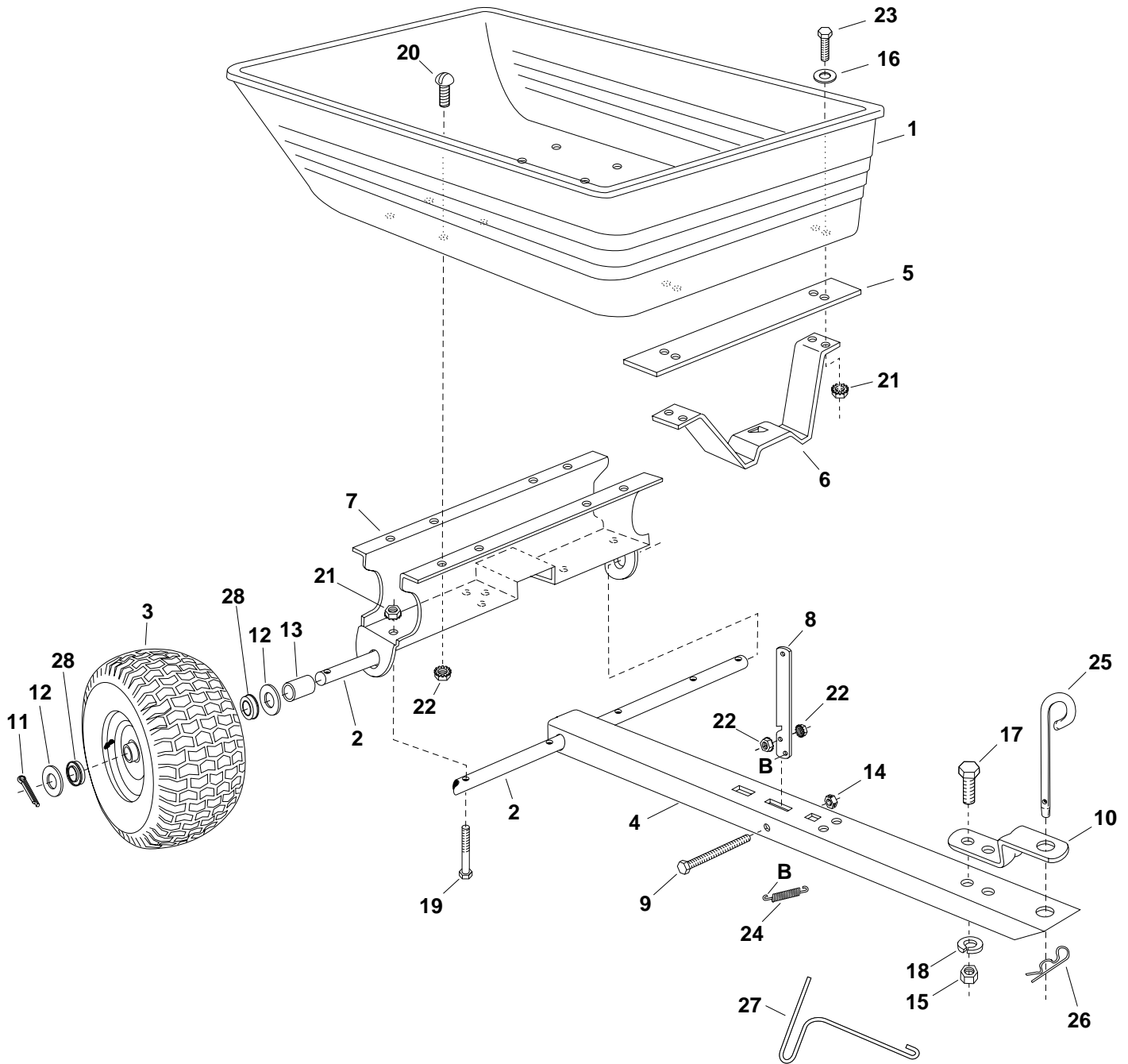

REPAIR PARTS LIST FOR POLY CART MODEL 45-0175

REF. NO.	PART NO.	QTY.	DESCRIPTION
1	47019	1	Poly Tray
2	24528	1	Axle, 1"
3	47049	2	Wheel
4	24758	1	Tongue, Draw Bar
5	24386	1	Latch Stand Plate
6	24497	1	Latch Stand Bracket
7	24527	1	Wheel Support
8	24498	1	Latch Lock Lever
9	47407	1	Hex Bolt 5/16-18 x 3-3/4"
10	23475	1	Hitch Bracket
11	43093	2	Cotter Pin, 1/8" Dia. x 1-1/2"
12	43601	4	Washer, Flat 1.59" OD x 1" ID
13	47453	2	Spacer Tube, 3-1/8" Lg.
14	43064	1	Hex Lock Nut 5/16-18*
15	43015	2	Hex Nut, 3/8-16*
16	43088	4	Washer, Flat 1/4"
17	43087	2	Hex Bolt, 3/8-16 x 1-1/4" *
18	43003	2	Lock Washer, 3/8" *
19	1509-69	4	Hex Bolt, 1/4-20 x 1-3/4" *
20	43814	8	Truss Head Bolt, 5/16-18 x 3/4"
21	46978	8	Hex Nut, 1/4-20 (SEMS)
22	46980	10	Hex Nut, 5/16-18 (SEMS)
23	43012	4	Hex Bolt, 1/4-20 x 3/4" *
24	47408	1	Extension Spring
25	23353	1	Hitch Pin
26	43343	1	Hair Cotter Pin
27	47622	1	Spring Puller
28	47512	4	Wheel Bearing
	48227	1	Owner's Manual

* Purchase Common Hardware Locally

For Agri Fab Discount Parts Call 606-678-9623 or 606-561-4983

SLOPE GUIDE

(Keep this sheet in a safe place for future reference.)

Use this guide to determine if a slope is safe for the operation of your tractor and cart. Refer also to the instructions in your vehicle owners manual.

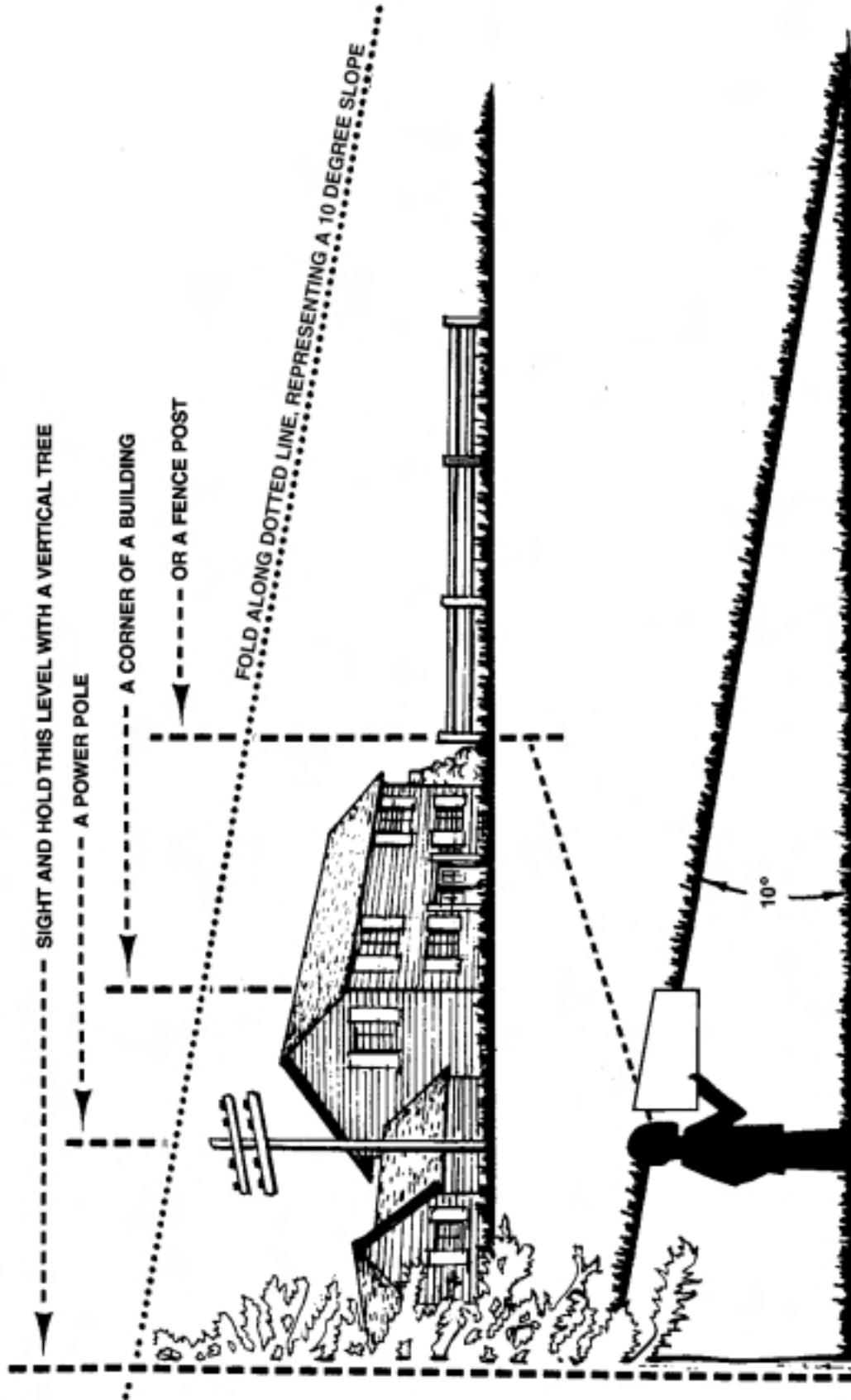

CAUTION: DO NOT OPERATE YOUR TRACTOR AND CART ON A SLOPE IN EXCESS OF 10 DEGREES. BE SURE OF YOUR TRACTOR'S TOWING AND BRAKING CAPABILITIES BEFORE OPERATING ON A SLOPE. AVOID ANY SUDDEN TURNS OR MANEUVERS WHILE ON A SLOPE.



For Agri Fab Discount Parts Call 606-678-9623 or 606-561-4983

SpeedEPart *the fastest way to purchase parts* www.speedepart.com

REPAIR PARTS
303 West Raymond
Sullivan, IL. 61951
217-728-8388
www.agri-fab.com

© 2001 Agri-Fab, Inc.

www.mymowerparts.com